

# EB 60 V

## Adjustable Edge Banding Slot Gun



*The evolution in edge banding - flexible and reliable. Nordson has developed this new slot nozzle technology for high quality adhesive application and sealing of wood edges.*

The application head EB 60 V is a mile stone for high product quality at lower production costs - the ideal alternative to the open glue roller systems traditionally used in the woodworking industry.

The applications for the EB 60 V include edgebanding, back edge sealing of substrates e.g. chipboards as well as soft forming.

The edgebanding application head of the EB series are highly flexible and are designed to apply a wide range of hot melt adhesives like EVA, polyolefines and polyurethanes (PUR) with viscosities from 10 000 to 100 000 mPas / cps\*).

The adhesive is applied through a slot nozzle. The coating width can be adjusted up to a maximum of 60 mm / 2.4". The width adjustments can be made easily by turning a handwheel. A scale allows precise readout of the chosen coating width, making the changes fast and reproducible.

The slim gun design and the spring loaded bracketry allow easy installation in existing edge banding machines, even when the available space is limited.

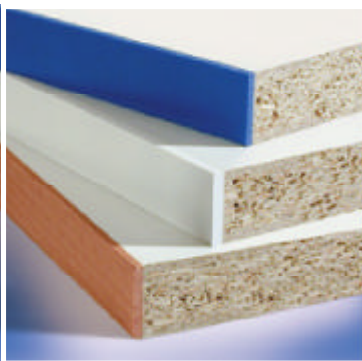

Supplied with adhesive from a Nordson hot melt application system via a heated hose, the temperature of the EB application head can be controlled with a precision of +/- 1°C / °F. This ensures good bonding quality due to a constant adhesive viscosity and prevents the adhesives



from charring or premature curing. The volumetric metering of the adhesive in the melter by precision gear pumps allows to improve product quality while saving significant amounts of adhesive. Other benefits of the closed EB slot gun system includes:

- no contamination
- no adhesive waste
- significantly less cleaning
- controllable and reproducible production process

\* Adhesives with viscosities of more than 100,000 mPas / cps were also processed successfully; higher viscosity materials should be tested prior to use.

# EB 60 V Adjustable Edge Banding Slot Gun



Edge banding

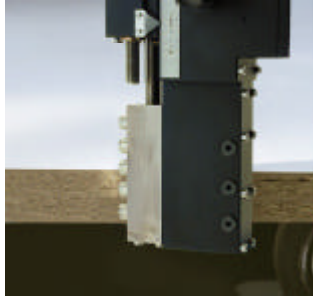

Backedge sealing

→  
Adjustment of the  
coating width by  
a „hand wheel“.

→  
Scale for precise  
readout of the  
coating  
width.

→  
Adjustable slot  
width.

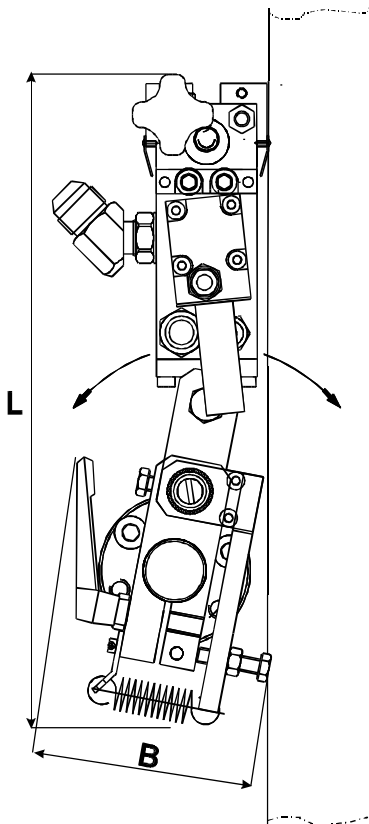

*The slim design allows installation  
in machines with limited space.*

## Specifications:

|                       |   |
|-----------------------|---|
| Operating temperature | max. 200 °C / 392 °F                      |
| Adhesive pressure     | max. 7 MPa / 70 bar / 1016 psi            |
| Application width     | max. 60 mm / 2.4 in                       |
| Temperature sensors   | FeCuNi, Ni 120                            |
| Air pressure          | 0.5 - 0.6 MPa / 5 - 6 bar / 7.3 - 8.7 psi |
| Operating voltage     | 230 V <sub>AC</sub> 50/60 Hz, 1phase      |
| Power consumption     | 300 W                                     |
| Dimensions (l x w)    | ca. 250 x 105 mm / 10 x 4.2 in            |
| Weight                | 6,5 kg / 14.3 lb                          |

*For more information, talk with your Nordson representative or contact your Nordson headquarters office.*

United States  
Duluth, Georgia  
Tel. (800) 683-2314  
Fax (770) 497-3733

Canada  
Markham, Ontario  
Tel. (905) 475-6730  
Fax (905) 475-8821

Europe  
Lüneburg, Germany  
Tel. (49) 4131-894-0  
Fax (49) 4131-894-149

Japan  
Tokyo, Japan  
Tel. (81) 3-5762-2700  
Fax (81) 3-5762-2701

Asia / Australia /  
Latin America  
Duluth, Georgia  
Tel. (770) 497-3400  
Fax (770) 497-3588



<http://www.nordson.com>



© 2000 Nordson Engineering GmbH  
All Rights Reserved  
Nordson reserves the right to make design changes between printings.

PAL-00-986 EN  
05/2000  
Printed in Lüneburg, Germany